

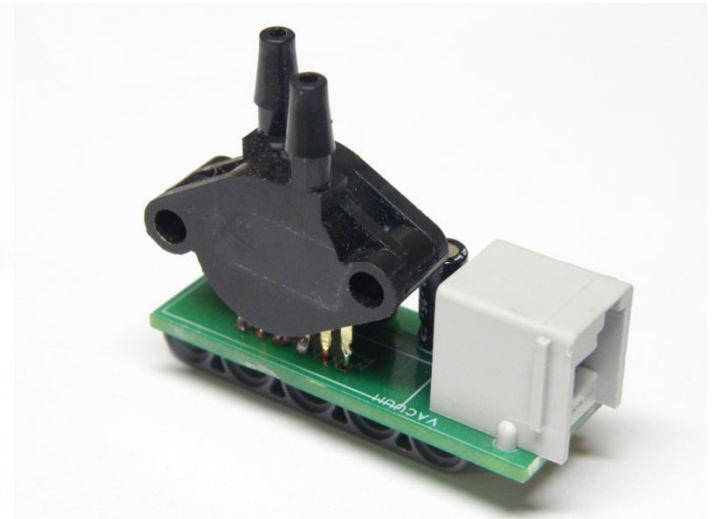

dexter industries

dPressure Sensor Manual

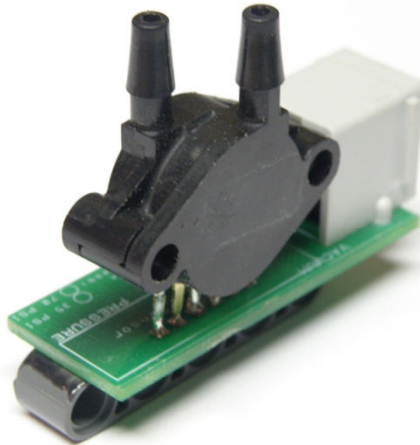

dPressure 250 – The dPressure 250 is a pressure sensor capable of measuring up to 250 kPa (30 psi) of pressure and gauge vacuum. The sensor can be attached directly to the Lego Mindstorms NXT. The sensor is easy to use and users can be up and reading pressures in seconds.

dPressure 500 - The dPressure 500 is a pressure sensor, similar to the dPressure 250, capable of measuring up to 500 kPa (70 psi) of pressure and gauge vacuum.

Version 1.1 Last Modified July 2010



dexter industries

Getting Started

Safety:

High pressures can be dangerous! Precautions should be taken. Wear safety goggles. Never use pressurized systems without adult supervision. Never use the sensor or any parts at pressures outside of their specified pressure tolerances.

Determine the Maximum Pressure:

First, check to see what model of dPressure sensor you received. The model can be determined by the circles next to the capacitors on the printed circuit board of the sensor. The model's maximum pressure should be checked on the PCB. *Operating the sensor above the maximum specified pressure can seriously and permanently damage the sensor. Do not use the sensor outside the specified pressure limit.*

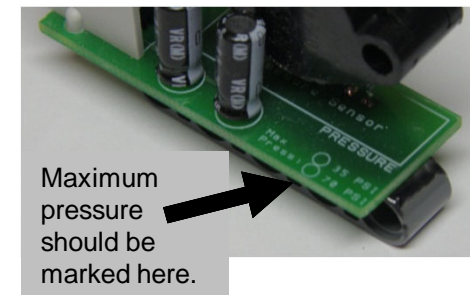

Select and Install the Correct Software:

After determining the maximum pressure of your sensor you should go to the Dexter Industries website (www.dexterindustries.com) and download the zip file for your specific sensor. Save to your computer, unzip the file, and install on your NXT software.

To install in NXT-G, go to "Tools" and select "Block Import and Export Wizard". Select the directory the files were unzipped in. Import the relevant file.



dexter industries

Hardware Setup

Connect with the Mindstorms NXT:

Connect the pressure sensor to one of the NXT data ports. No adapters necessary.

Secure the Sensor:

Using the Technic brick under the sensor, attach the sensor to your robot, laboratory setup, or other device. For non-Lego attachments, an easy way to attach the sensor is with zip ties through the brick holes.

Secure tubing to the Sensor:

Gauge Pressure: The pressure-port on the sensor is the port on the capacitor-side of the plastic.

Gauge Vacuum: The vacuum-port on the sensor is the port opposite the capacitor-side of the sensor.

For both ports, the 1/8" ID tubing can be used to connect with the sensor. For Lego-Pneumatic applications an adapter is enclosed. For pressures over 15 PSI, we recommend you place a small hose clamp over the area where the hose overlaps with the port.

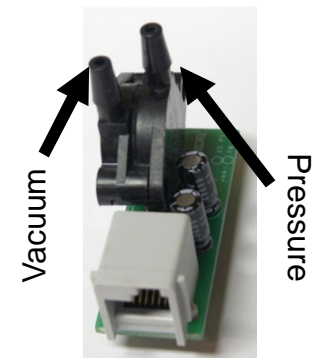
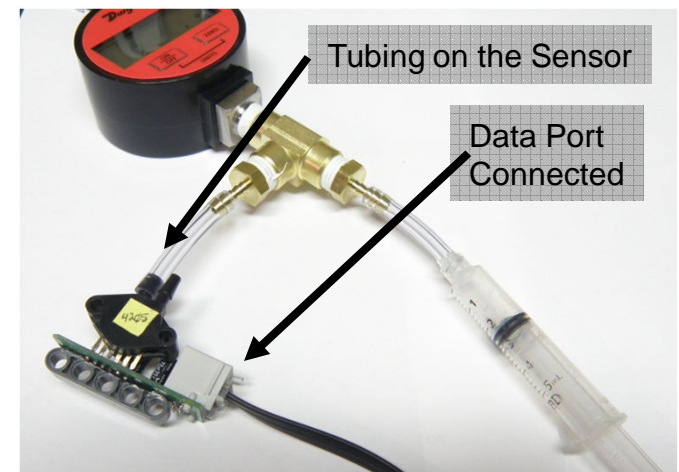



dexter industries

Using the NXT-G Block: 3 Easy Steps

Drag the Block From the Palette into Position:

In NXT-G, select the appropriate “dPressure” block and drag it out onto the work area of your screen.

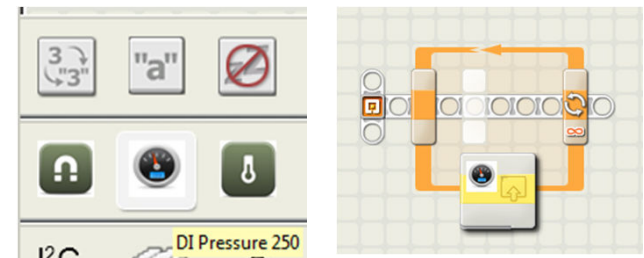

Specify the port the dPressure is plugged into:

In the block dialogue box at the bottom of the screen, specify which sensor port the sensor is plugged into. In the example to the right, the dPressure is plugged into port 1.

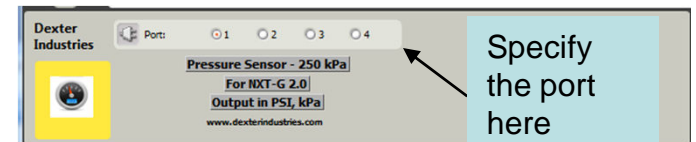

Link the dPressure sensor to other blocks:

Click on the brick to drop the wiring menu down. Four options are offered: a port specification (to automatically set the port the block reads from), data output in PSI, raw sensor data, and data output in kilopascals (kPa). In the example to the right, we've placed the dPressure in a continuous loop that reads pressure and puts the value, in PSI, onto the screen.

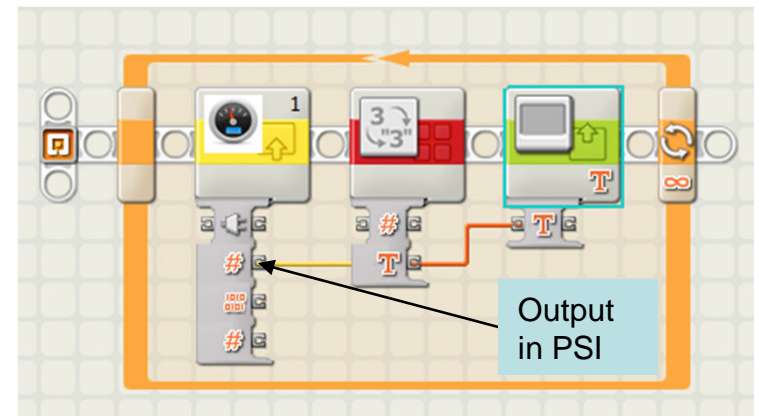



dexter industries

FAQ

Q: What type of sensor is the dPressure?

A: The dPressure is an analog differential pressure sensor.

Q: What size are the port openings on the dPressure sensor?

A: The dPressure sensor port openings fit to 1/8" tubing. Each sensor comes with an adapter to fit to Lego Pneumatic hosing.

Q: What is the minimal pressure difference the sensor is able to read?

A: Using NXT 2.0 and the dPressure block, the sensor can read down to 0.04 PSI (0.27 kPa). The sensor typically moves in increments of 0.04 PSI.

Q: What is the sensor time response?

A: The sensor time response is limited to the NXT and Firmware. The sensor itself provides a response within 1 ms.

Q: Will operating at a higher pressure than the rated pressure damage the dPressure sensor?

A: Yes, yes it could. We have not destructively tested the sensors, but overloading any sensor can damage the sensor, and could result in unsafe operation.

Got a question? Write us at info@dexterindustries.com